

Range: Single deck-mounted sensor tap

Ref: 55389 - PRESTO NOVA

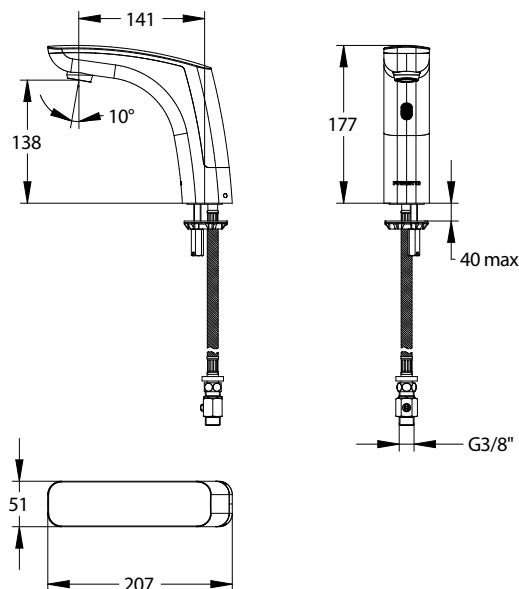

> Working pressure :

- 1 to 5 bar

> Flow :

- 3 l/min with integrated flow limiter
- High quality anti-limescale aerator
- Anti-water-hammering design

> Hydraulic supply :

- G 3/8" (12x17) - Cold or premixed water

> Power supply :

- Integrated 6V CRP2 lithium battery

> Material and colour finish :

- Injected molded metal body and cover
- Matte Black finishing

> Thermal resistance :

- Resistant to a temperature of 75°C for 30-minute-thermal-shocks

> Security :

- Anti-overflow security time: 30 seconds
- Anti-blocking system preventing the water to flow continuously

> Delivered with :

- 1 Brass clamping nut
- 1 Gasket and 1 Washer
- 1 Hose with revolving nut
- 1 Stop valve MM G 3/8" (12x17)
- 1 Filter gasket
- 1 Self-adhesive sticker
- Instruction manual

> Standards & approvals :

- Brass body in accordance with NF EN1982, EN12164, NF EN 12165
- 200-hour neutral salt spray resistant (NSS) in accordance with NF ISO 9227

